

INLINE HAND SLIDE GATE - HDPE / RVS316L TYPE SPIGOT END FOR SOCKET/COUPLING MOUNTING (S), Ø110 - 315 MM.

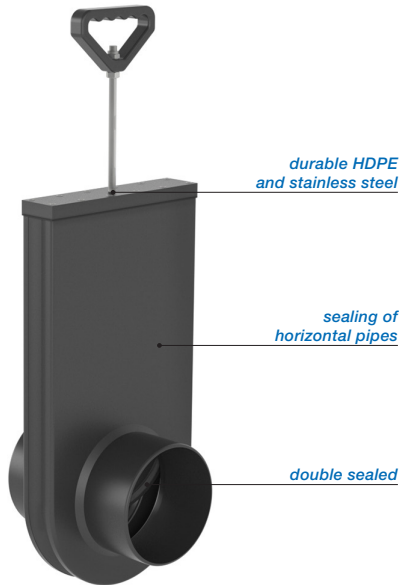

The Freedrain® inline hand slide gates are used in surface water, sewage and process water. These slide gates are manufactured in our own factory from high quality HDPE and are equipped with a stainless steel control rod, which is sealed in the valve body by means of a special designed double Lips sealing ring. Both the housing and sliding plate are made of HDPE. Furthermore, the control rod will be equipped with an HDPE handle and a comfortable grip. This design is suitable to withstand a water pressure in On and Off seating situation, by using an EPDM lip seal on both sides of the slide plate.

The gates are suitable for a maximum working pressure of 1 till 3 meter water column. Standard, the inlet and outlet are equipped with a welded spigot suitable for connection with a coupler. As option they can be equipped with a flange. Custom made solutions are possible on request. The hand slide gates can be used both above and below ground. They are designed to use in horizontal pipes only.

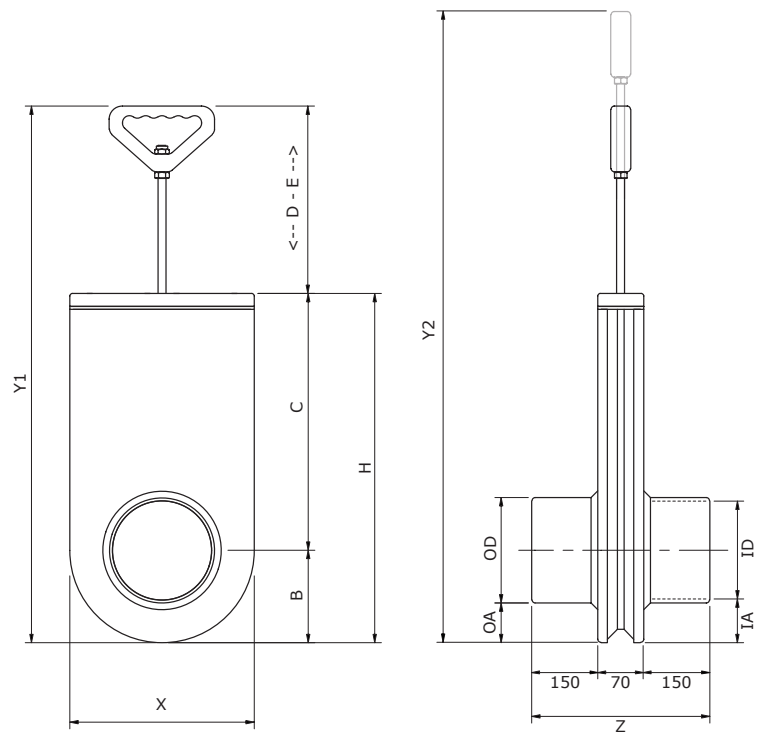

Advantages:

- Easy operation. Remains automatically in "open position".
- Manufactured from durable material HDPE and stainless steel.
- Easy to install.
- Custom made possible.
- Seals and packing are easy to replace.

Other options:

- Available with welded protection shaft.
- Available with PN10 flange.
- Other PN flanges also possible on request.
- Optionally available with extended stainless steel control rod.



type Freedrain®	DN mm.	X mm.	Y1-Y2 mm.	Z mm.	ID mm.	IA mm.	OD mm.	OA mm.	B mm.	C mm.	D-E mm.	H mm.	approx. weight
670.AHL.0110S	Ø110	245	778 - 945	370	Ø102	65	Ø110	61	116	345	317-484	460	± 6 kg.
670.AHL.0125S	Ø125	245	778 - 945	370	Ø115	65	Ø125	60	123	338	317-484	460	± 6 kg.
670.AHL.0160S	Ø160	280	815 - 1015	370	Ø150	65	Ø160	60	140	390	284-484	530	± 8 kg.
670.AHL.0200S	Ø200	320	850 - 1094	370	Ø185	65	Ø200	57	157	452	241-484	610	±10 kg.
670.AHL.0250S	Ø250	370	895 - 1194	370	Ø231	65	Ø250	55	180	530	185-485	710	±13 kg.
670.AHL.0315S	Ø315	440	1000 - 1360	370	Ø231	70	Ø315	58	215	660	125-485	875	±20 kg.

Dimensions in millimeters, weights in kilograms. Subject to changes in images, dimensions and description. Placement, installation and use in accordance with our regulations.